

# Lifting Solutions

## MINIFOR TR50

### 0.5t Portable motorised wire rope hoist

Hoists are often used in conjunction with glass vacuum lifters and used for applications such as ground level shop front glass installation.

Faster than the TR30 and with a 500kg capacity, the TR50 hoist also boasts a 2.5m pendant control cable with emergency stop function.

**We provide competitive rates on both short and long term hire on our material hoists.**



#### Technical Specifications

Manufacturer	Minifor
Power Source	Mains
Lifting Capacity	500KG
Power	110 Volts

#### Features

- 2.5m remote cable as standard
- Long wire rope length
- Easy to use, lightweight and powerful
- Emergency stop function
- Quick installation

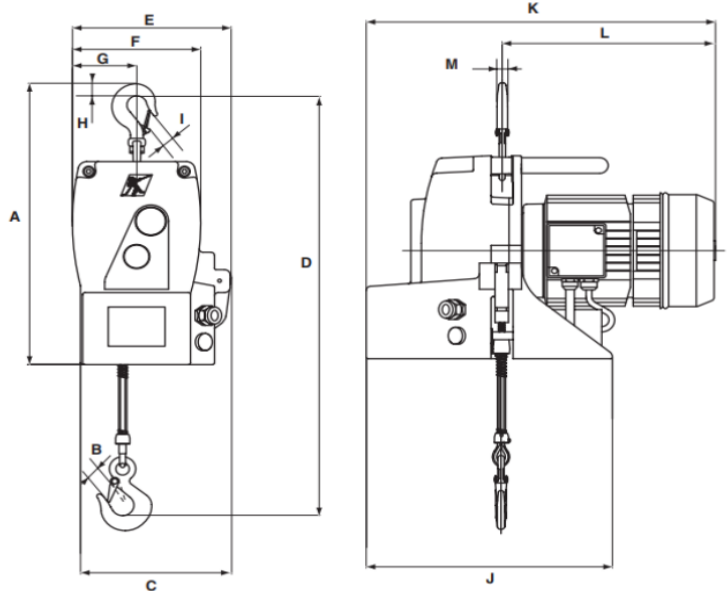

Model	WLL		Speed		Dimensions mm														Weight (KG)
	Direct KG	Sheaved KG	Direct m/min	Sheaved m/min	A	B	C	D	E	F	G	H	I	J	K	L	M		
TR50	500	950	7	3.5	430	20	212	642	224	181	90	20	20	347	492	302	15	31	